

TABLE TOP TEMPERER

with Digital Temperature Readout



INSTRUCTION MANUAL

American Chocolate Mould Company

1401 Church Street - Unit #5 · Bohemia, NY 11716

Phone (631) 589-5080 · Fax (516) 908-3660

amerchoc@mindspring.com · www.americanchocolatemould.com

Table of Contents

Important Safeguards	2
Contents of Box	3
Introduction	3
New Machine Setup Procedure & Orientation	4
Getting Ready to Turn On the Machine	5
To Power Up the Machine	7
Start Up for Chocolate (tempering)	9
Start Up for Compound Coatings	10
Re-tempering Instructions for Chocolate	11
Overnight Shut Down of the Machine	12
Daily Operation	13
Changing Coatings	14
Coating Quality & Coating Luster	15
Coating Quality Control Troubleshooting Guide	17
General Troubleshooting Guide	18
Cleaning Instructions	19
Table Top Temperer Exploded Diagram	20
Table Top Temperer Spare Parts List	21

Important Safeguards

Read and Understand for YOUR safety

When using electrical appliances, basic safety precautions should always be followed. Please adhere to the following guidelines:

1. Read ALL instructions thoroughly. If any part of the instruction is not clear, please contact APMC for clarification.
2. To protect against the risk of electrical shock, do not put the machine in or near water or any other liquid.
3. Not recommended for use by children.
4. To avoid shock, do not attempt to repair or service machine. Repairs should only be made by an authorized service person.
5. The Table Top Temperer should be installed according to the National Electric Code. The Table Top Temperer should be connected to a grounded outlet.
6. Do not operate any appliance with a damaged cord or plug.
7. Use the Table Top Temperer only for melting and tempering chocolate and compound coatings.
8. Do not operate this or any other motor driven appliance while under the influence of alcohol or other substances that may seriously affect your reaction time or perception.
9. The main switch in the back of the machine **MUST BE IN THE "OFF" POSITION** before removing the bowl.

Contents of Box

- 1 - Table Top Temperer
 - 1 - Clear Lexan cover
 - 1 - 6 foot power cord
 - 1 - 5 quart stainless steel melting bowl
 - 1 - Bowl scraper
 - 1 - Instruction manual
 - 2 - 3 AMP slow fuse (1 is installed). There is 1 spare fuse located in the fuse holder below the main power switch in the back of the machine.
- Note: Power cord must be removed first before the fuse holder can be opened.*

Introduction

The Table Top Temperer has been tested and inspected before it left the factory. Care has been taken to see that your machine arrives free from damage. To accomplish this, every precaution has been taken to see that the Table Top Temperer is properly packaged for shipping. As you unpack the machine, please inspect it for any damage which may have occurred in shipping. If any damage has occurred to your machine in shipment, please contact the Customer Service right away.

TO PREVENT PERSONAL INJURY and damage to the machine, it is imperative that you read the Instruction Manual before powering up the Table Top Temperer.

After unpacking the Table Top Temperer, it will be necessary for you to prepare the machine for operation and learn the function and location of the different parts of the machine.

Please **RETAIN THE BOX FOR WARRANTY** and repair purposes. Machine must be returned in the original box for all warranty and repair work. Machines that are returned not in the original box may void any warranties implied. There will be an additional charge for a new box if the Table Top Temperer is not returned in its original box.

New Machine Setup Procedure and Orientation

*** Make sure the MACHINE IS NOT PLUGGED IN ***

1. Remove the Clear Lexan Cover.
2. Loosen the two wing nuts holding the bowl scraper down.
3. Remove the temperature probe from its holder in the bowl scraper by pulling it straight up and out of its holder. **NEVER PULL THE PROBE OUT BY THE ITS WIRE** or try to remove the probe once the chocolate has solidified (denting the casing can damage the probe). Always use care when handling the probe.
4. Twist the bowl scraper counter-clockwise to disengage it from the nylon hold-down studs and remove it from the bowl.
5. Remove the mixing bowl by lifting it up and out of the housing and drive plate.
6. On either side of the drive plate are heating lamps. Check to see that the light bulbs are properly seated in the sockets. **NEVER ATTEMPT** to remove the bowl or change the light bulbs when the machine is plugged in or bulbs are hot.
7. Replace the mixing bowl into the machine housing making certain to engage the coupling pins into the drive plate. After placing the bowl into the housing, rotate the mixing bowl in a slow clockwise direction until you feel, hear and see the bowl drop into place. Once the bowl is properly seated, it will not turn freely. **NEVER ATTEMPT** to rotate the mixing bowl manually after it is engaged in the drive plate. This action can damage the drive plate and gear box.
8. Place the bowl scraper into the bowl and rotate it in a clockwise direction until the hold-down studs are captured in the bosses on either end of the scraper. Tighten the wing nuts until they are snug. **DO NOT OVER TIGHTEN THE WING NUTS.** Over tightening the wing nuts may force the bowl scraper to interfere with the rotation of the bowl and could cause the scraper to bind against the bowl thereby damaging the scraper, gearbox and motor. See “Adjusting Bowl Scraper” section (Page 8). Be sure the probe holder is facing the front of the machine.
9. Slide the probe into its holder on the bowl scraper until it rests on the lip of the scraper at the bottom of the bowl.

Getting Ready to Turn On the Machine

Before powering up the machine, it is important that you familiarize yourself with the function, location, and operation of the various controls on the Table Top Temperer.

Power Module

The Table Top Temperer is outfitted with a power module that will accept a detachable cord set and incorporate into it a main power switch and fuse holder. The power module is located on the lower back housing of the machine. The machine is designed to operate on the 115 volts AC at 60 Hz (overseas models have 200 volt AC).

Control Panel

LED Indicator Lamps

The main control panel on the front of the machine is equipped with an array of LED lamps that indicate the status of the machine. The red digital readout, when illuminated, indicates that the main power switch is on and that the machine is fully powered. The yellow LED, when illuminated, indicates that the machine is in the heating cycle and the light bulbs are on. The green LED, when illuminated, indicates that the machine is in a cooling cycle and the exhaust is cooling the mixing bowl.

Thermostat

On the right side of the control panel are the temperature control push-button switches having a temperature range from 70°F to 125°F. To observe the set point, you must press in on the temperature set switch. To change the set point, PRESS and HOLD the temperature set switch and press the up or down arrow to obtain the temperature desired. Release the temperature set switch and the display will indicate the temperature of the mass in the mixing bowl.

Note: The temperature cannot be changed unless the temperature set switch is held in while pressing either the up or down arrows.

Bowl Motor Switch/Bowl Motor

Below the temperature control panel is a rocker switch that controls the bowl motor. Depressing the left side of the rocker switch turns the bowl motor on and depressing the right side turns the motor off. The bowl motor operates on at 115V AC @ 60Hz and rotates in the clockwise direction. Do not attempt to rotate the bowl or drive plate by hand as this can damage the gear box and motor.

Cord Set

The detachable cord set has a molded three prong male plug on one end and a molded female machine plug on the other end.

Light Bulbs

The machine is equipped with two 100 Watt heavy duty light bulbs. Please replace with the same type bulbs. We recommend the GE Survivor light bulbs, as they are vibration resistant.

To Power Up the Table Top Temperer

Plug the female end of the power cord into the power module located at the rear of the machine. Before plugging the male end of the power cord into the wall outlet, make sure that main power switch is in the OFF position. The bowl motor switch should also be in the OFF position. The machine is designed to operate on 115V AC at 60Hz and should be plugged into a grounded outlet. If the machine is properly connected, the red digital readout on the front panel will illuminate, as well as either the HEAT or COOL LED.

The machine is now fully powered and ready for use.

We recommend that you become familiar with the bowl motor control and thermostat before loading the bowl with chocolate.

The ON/OFF switch for the bowl motor is located on the lower right hand corner of the control panel. Turn the motor ON and observe that the bowl rotates in a clockwise direction.

The temperature control is an electronic digital type of control. If the COOL LED is illuminated and you press and hold the temperature set switch and press the up arrow (setting the temperature at a higher level), the fan will turn off and the light bulbs in the machine will come on. The light bulbs will stay on until the bowl temperature reaches the set point. Once the set point is reached, the light bulbs turn off and the cooling fan will come on. Conversely, if you observe that the light bulbs are on and you press and hold the temperature set switch and press the down arrow, the light bulbs will shut off and the cooling fan will start. The machine will automatically cycle between heating and cooling maintaining the temperature at which it is set.

Note: *The machine is designed to maintain the set temperature to plus or minus 1 degree. When you first start up the machine, it may take 30-40 minutes (depending upon the bowl temperature, room temperature, and set point temperature) for the cycle to level out and maintain a stable temperature.*

**The TABLE TOP TEMPERER is now ready
to be filled with chocolate for tempering.**

Bowl Scraper/Adjustment

The scraper's function is to keep the melted chocolate and tempered chocolate in the front portion of the bowl and the solid chocolate in the rear portion of the bowl. The scraper is designed to properly fit the bowl so that the thin wiper sections along the perimeter of the scraper maintain continuous intimate contact with the bowl.

The scraper is properly adjusted when the chocolate is wiped clean from the left side of the bowl as it rotates.

***Note:** Do not over tighten the scraper. Over tightening of the scraper will interfere with the smooth rotation of the bowl and can damage the drive plate, motor, and/or gear box. If scraper cannot be adjusted to properly clean the bowl and you have used your Table Top Temperer on a regular basis, the scraper may be worn. If this occurs, please replace the scraper.*

Start-Up for Chocolate

The chocolate you have purchased (whether it is in block or wafer form) has been tempered by your supplier. Therefore, you are given two options:

1. Using the Supplier's Temper
2. Complete Tempering Process

If you are starting the Table Top Temperer when there is no chocolate or compound in the bowl from previous work sessions, the following steps should be followed:

Option 1: Using the Supplier's Temper

1. Turn on the main power switch in the back of the Table Top Temperer.
2. Set the temperature control to 99°F.
3. Load 2 to 3 pounds of small (1/2") broken chocolate pieces or wafers equally distributed in both the front and back side of the scraper. The smaller the pieces or wafers, the quicker the mass will melt. The bowl scraper divides the mixing bowl into a rear melting section and a front section holding the tempered chocolate. The dust cover should be put on at this time to hasten the melting process.
4. After approximately one half of the chocolate is melted in the bowl, the bowl motor switch can be turned on. As the bowl rotates, the melting chocolate will move from the rear melting section of the bowl to the front section of the bowl.
5. Set the temperature to (suggested) 88-89° F and wait until the chocolate has cooled to this temperature.
6. When you have approximately three inches of melted chocolate in the front of the bowl, you can start to use the chocolate. You can add fresh broken chocolate to the REAR SECTION of the bowl to replenish the chocolate you are using. Maintain the temperature at 88-89° F.

7. Maintain room temperature at approximately 68-70°.
8. Relative humidity must be 50% or lower.
9. Dark chocolate may require approximately 1-2° higher.
10. If chocolate has been kept for some time or if re-tempering is required, follow instructions on page 11.

Option 2: Complete Tempering Process

(Refer to page 11 “Re-tempering Instructions for Chocolate”)

Note: Temperatures vary for each type of chocolate. The above listed temperatures are the approximate temperature settings. We suggest you follow the instructions from your chocolate supplier for the exact setting that should be used.

Start Up For Compound Coatings

Follow the same procedure as for chocolate as instructed on pages 9 and 10, but set the temperature to approximately 95°F and maintain this temperature setting. Please note that this setting is approximate. We suggest you follow the instructions of your coating manufacturer.

Re-Tempering Instructions for Chocolate

The following instructions are intended as a guide in tempering chocolate. All temperatures are approximate. There are many factors which will affect the tempering of chocolate (age, manufacturer, type of chocolate, room temperature, humidity, drafts, etc.). Please follow your manufacturer's suggestions.

We suggest the following guidelines:

1. Set the temperature control to 115°F.
2. When the fan comes on, the temperature should be at 115°F (check the digital reading). The bowl should now be rotating.
3. Make sure all the chocolate is melted and there are no lumps. You may have to scrape the sides of the scraper blade to be sure all of the chocolate is well mixed. We suggest you use plastic utensils. With the bowl rotating, continue to mix chocolate for 10-20 minutes at 115°F.
4. Set the temperature control to approximately 82-83°F. You can now add some small shavings of fresh tempered chocolate directly into the hot chocolate. This will help to bring down the temperature and start the tempering cycle. When the temperature has reached 82-83°F, the fan will shut off and the heating lights will come on. Check the temperature on the thermometer at this time. Scrape all sides and corners to make sure the chocolate is mixed. Continue to mix for approximately 10 minutes.
5. Set the temperature setting to 86-87°F for milk chocolate. When the chocolate has reached this temperature, scrape all surfaces again. Let the chocolate mix for approximately 10 minutes at 86-87°F. The chocolate should now be ready to use.

***Reminder:** Dark Chocolate should be set 1-2° HIGHER than milk chocolate.*

DO NOT TURN ON BOWL MOTOR until chocolate or compound has been melted. Damage may occur to the drive mechanism when there is solid chocolate or coating in the bowl.

Overnight Shut Down of the Machine

If you WILL be using the SAME CHOCOLATE the FOLLOWING DAY:

1. Turn off the bowl motor.
2. Remove enough chocolate so that only 2 -3 pounds are left in the bowl.
3. Set temperature to 99°F.
4. Place the Clear Lexan cover on the machine.

This procedure will keep the chocolate melted overnight and permit for a quick startup in the morning.

If you WILL NOT be using the same chocolate the following day:

1. Turn off the bowl motor.
2. Remove the probe from the bowl scraper.
3. Remove the bowl scraper from the bowl by loosening the wing nuts and rotating the scraper so that it is free from the studs. Lift the scraper out of the bowl.
4. Turn off the main power switch in the rear of the machine.
5. Lift the mixing bowl out of the housing.
6. Remove the chocolate from the mixing bowl.
7. Clean the mixing bowl and scraper and return it to the machine.

Daily Operation

If you are starting with chocolate that has been kept melted overnight at 99°F, the following procedures should be followed:

1. Remove the Clear Lexan cover.
2. Turn on the bowl motor.
***Important:** Inspect the melted chocolate to see if it is melted throughout and not solidified below the surface around the bowl scraper. Starting the bowl motor with chocolate solidified around the scraper can DAMAGE the scraper, motor and gear housing.*
If the chocolate has solidified around the scraper, check the temperature setting to make sure that both light bulbs are operating.
3. Let the chocolate mix thoroughly at 99°F for 10 minutes. Be sure to mix in any chocolate that has collected on the scraper surface.
4. After you are sure all the chocolate has been mixed, set the temperature to 88° for milk and 90°F for dark chocolate. At this time, you must add fresh shavings of chocolate to the melted chocolate. You can also add pieces of fresh broken chocolate to the rear section of the bowl.
***Note:** When you lower the temperature to 88 or 90°F, the heat lamps and heat indicator lamp will turn off. The cooling fan will start and the cooling indicator lamp will illuminate. The fan will stay on until the chocolate reaches the temperature setting. At this time, the heating lamps and cooling fan will begin to cycle on and off to maintain the desired temperature setting.*
5. After the chocolate has reached the desired temperature, you must run the machine for another 10 minutes to be sure all of the chocolate has stabilized to the set temperature.
6. The chocolate will now be in temper and ready to use.
7. When you have completed your daily production and are ready to shut down the machine, please refer to the section “Overnight Shutdown” on page 12.

***Note:** Refer to manufacturer’s recommended temperature settings*

Changing Coatings

To change coatings from light to dark, we suggest that you remove all of the coating around the bowl, scraper and probe.

When changing from light to dark coating, the dark coating will tolerate approximately 5% of lighter coating without affecting the darker coating's appearance.

When changing from a dark to a light coating (or to a white or pastel) it is recommended that the bowl, scraper and temperature probe be thoroughly cleaned to prevent the lighter coating from being discolored or streaked with the darker coating.

***Note:** Follow cleaning instructions if you have to clean the Table Top Temperer before changing coatings.*

Tip: One of the unique features of the Table Top Temperer is the ability to change bowls by simply lifting the bowl and scraper out and replacing it by dropping another into place. If you use a variety of coating, we recommend that you use a different bowl for each coating. This will enable you to quickly change from one coating to another without a long and tedious cleaning process between coatings.

Additional bowls and scrapers can be purchased by calling our Customer Service Department.

Coating Quality

The appearance of coated chocolate is subjective in terms of its aesthetic qualities. The following tips are provided to help you control the thickness and luster of your coated chocolates.

The Table Top Temperer has been designed and manufactured to provide a quality machine for tempering any type of chocolate coating. Although we have endeavored to design and produce the finest machine, there are other factors which will affect the aesthetic quality of your coated chocolates. These factors include (and are not limited to) coating room temperature, humidity, airflow, type of coating used, the core being coated and the rate at which the melted coating is being used and replenished. It is generally understood that each of these factors will affect the overall coating quality and each and all must be carefully considered when attempting to optimize your coating quality.

Coating Luster

The following tips are offered to help you maintain a quality luster on your coatings:

1. Optimum room temperature should be between 68-70°F. Room temperature should not exceed 72°F.
2. Room humidity should not exceed 50%. Chocolate coatings are very sensitive to humidity. Excessive humidity will damage chocolate coatings.
3. Coated chocolates should be cooled between 60-69°F. The room should be air conditioned and provide a light air flow over the chocolate as it cools.
4. Properly tempered chocolate will begin to set within 2 minutes and will be fully ready to handle within 5-10 minutes.
5. Monitor the melted coating for proper temper. If it is too thick (too cold) then increase the temperature setting by 1°. If it is too thin (too hot) decrease the temperature setting by 1°.
6. Special coatings such as white, pastel compounds, dietetic and carob coatings can be used and should be melted using the manufacturer's specified temperature settings.

7. Moist or creamy centers should be chilled prior to coating to enable the coating to freeze on the center more easily.

Remember: *Dark chocolates produce a higher luster than milk chocolates.*

Coating Quality Control Troubleshooting Guide

Coating Appearance		Cause	Remedy
Top	Bottom		
Cloudy	Cloudy	Coating too cold	Increase temperature 1 -2°
Dull (low luster)	Acceptable	Coating not properly tempered	Increase temperature 1 -2° and/or add chocolate
Cloudy	Shiny	Coating too hot	Decrease temperature 1 -2°
Spots	Cloudy	Coating too hot	Repeat daily startup procedure
Wet & sticky	Wet & sticky	Coating too hot (no temper)	Repeat daily startup procedure
Acceptable	Cloudy	Cooled too slowly	Cool with more air movement
One side cloudy	Acceptable	Cooled too fast	Move away from air source or increase air temperature
Moisture on surface	Coating sweats	Cooling air too cold	Do not refrigerate. Cool at 60-65°F with low humidity
Acceptable on day coated, but cloudy the next day		Cooled too slowly	Cool with more air movement

Tempering Machine Troubleshooting Guide

Problem	Cause	Remedy
Machine does not power up	Power cord not connected to machine or outlet correctly	Properly insert power cord into power module
	Fuse in machine is blown	Replace fuse in machine
	Circuit breaker or fuse on outlet is tripped	Replace or reset circuit breaker on outlet
Coating will not melt	No heat	Replace light bulb(s)
	Temperature control set too low	Set temperature to 95-100° F
Coating melts too slowly	Temperature control set too low	Set temperature to 95-100° F
	Light bulb(s) are blown	Replace light bulb(s)
	Coating level too low in rear of bowl	Add additional coating to bowl
	Bowl will not rotate	Turn bowl motor on or replace bowl motor
Coating will not cool to temper	Fan not working	Replace fan
	Temperature control set too high	Set temperature to 86-88° F
	Coating level too low in rear of bowl	Add additional coating to bowl
	Room temperature too high	Cool room to below 75° F
Bowl will not turn	No power	Properly insert power cord into power module or replace fuse in machine
	Set screw(s) on drive wheel are loose	Tighten with 3/32" Allen wrench
	Coating is not melted	Melt coating that has solidified around the scraper

Cleaning Instructions

Attention: To prevent against the risk of electrical shock, unplug from outlet before cleaning.

Machine Housing and Dust Cover:

It is recommended that the machine housing and dust cover be wiped down with a damp cloth or sponge using warm water and a mild detergent. Do not use an abrasive cleaner or steel wool pad on the machine housing or cover as this will scratch the surface.

Bowl Scraper:

The bowl scraper is dishwasher safe if placed on the top rack. If you are manually washing the scraper, please use warm water and a mild detergent. Do not use an abrasive cleaner or steel wool pad on the scraper as this will scratch the surface.

Bowl:

The inside of the bowl can be cleaned using an abrasive plastic cleaning pad with hot water and a mild dish detergent. We recommend that the exterior painted surface of the bowl be cleaned using a non-abrasive sponge or cloth in warm water with a mild detergent.

Temperature Probe:

The probe should be wiped clean using a non-abrasive cloth and warm water with a mild detergent.

DO NOT submerge the probe in water as this will damage it.

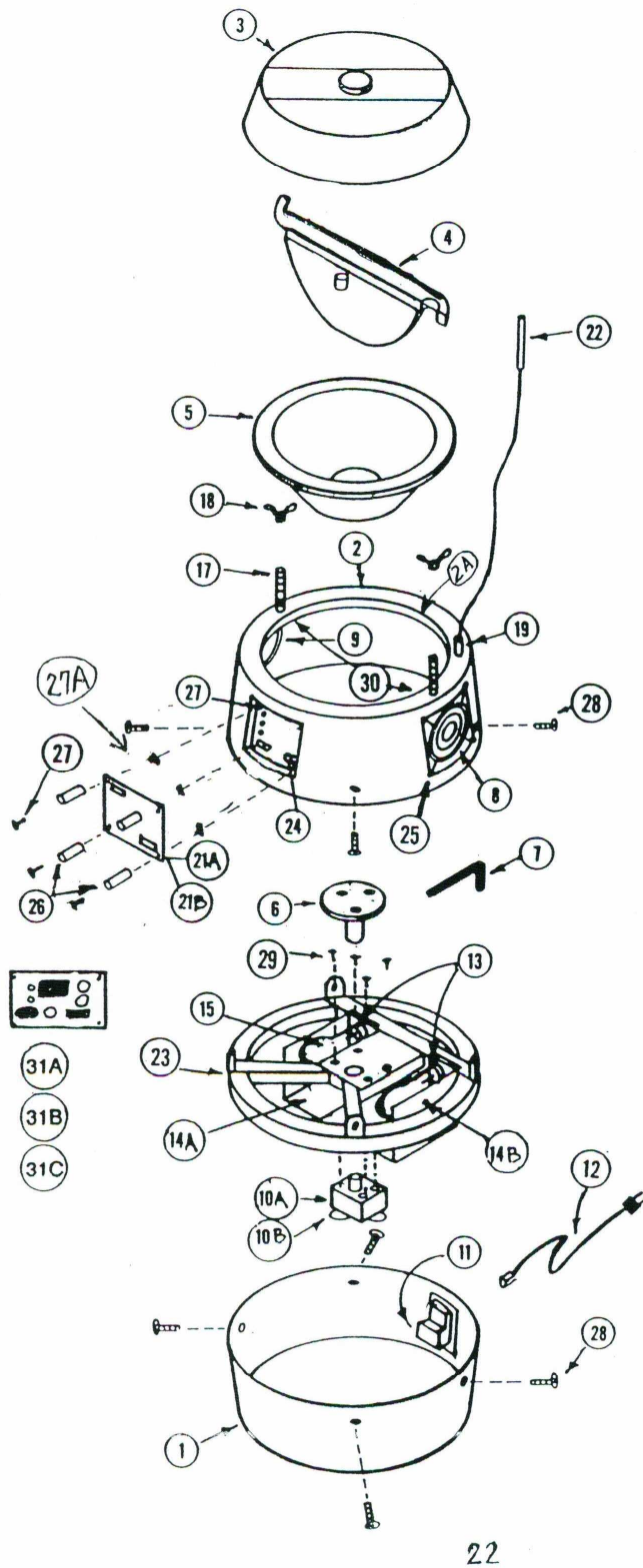

POWER CORDS

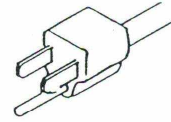

A. USA / CANADA

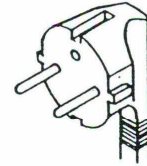

B. EUROPE

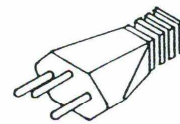

C. SWITZERLAND

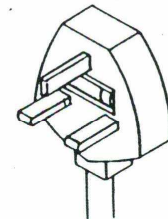

D. UNITED KINGDOM

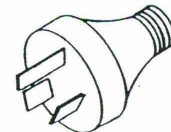

E. AUSTRALIA

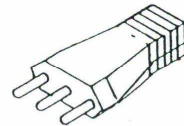

F. ITALY

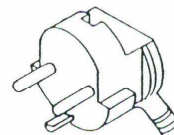

G. DENMARK

I. SOUTH AFRICA

K. ISRAEL

Parts List

(see diagram on previous page)

Item #	Quantity	Description of Item
1	1	Lower Housing
2	1	Upper Housing
2A	1	Anti-friction rim clip
3	1	Clear plastic dust cover
4	1	Scraper
5	1	Stainless steel bowl
6	1	Drive plate / gear
7	1	Allen wrench 3/32"
8	3	Grill / metal guard
9	1	Cooling Fan (AC Fan) 110V or 220V
10A	1	Drive motor 115V or 220V
10BV	1	Motor Cooling Fan
11	1	Power cord receptacle
12	1	Power cord
13	2	Ceramic lamp base assembly
14A	1	Light reflector set - left
14B	1	Light reflector set - right
15	2	Light bulb 115V/100W or 220V/100W
17	2	Nylon stud threaded 3/8-16
18	2	Nylon wing nut 3/8-16
19	1	Cord restrainer
21A	1	Control circuit board 115V
21B	1	Control circuit board 230V
22	1	Temperature probe (thermocouple assembly)
23	1	Plastic inner ring (only)
24	1	Rocker switch / kettle motor
25	16	Rivets 1/8 diameter x 1/2
26	4	Nylon spacer for circuit board
27	4	Metal screws for circuit board
27A	4	Metal nuts for circuit board
28	8	Self-tap screws 8-18x3/4" (self-drilling)
29	4	Motor mounting screws & washers (8-32x1/2")
30	2	Nut 3/8-16 for nylon studs (zinc plated)
31A/B/C	1	Control Panel label English, Spanish or German